

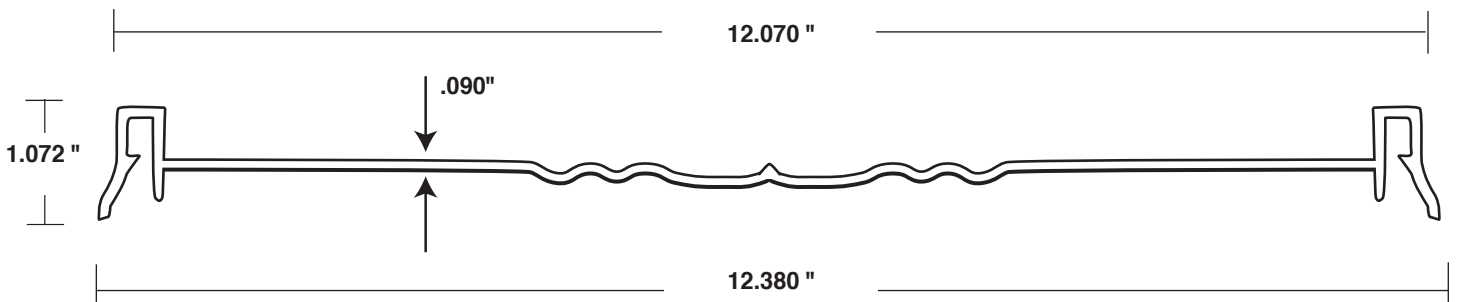

Standard Lid with Gasket

PART NO.: 205667

DATE: July 2010

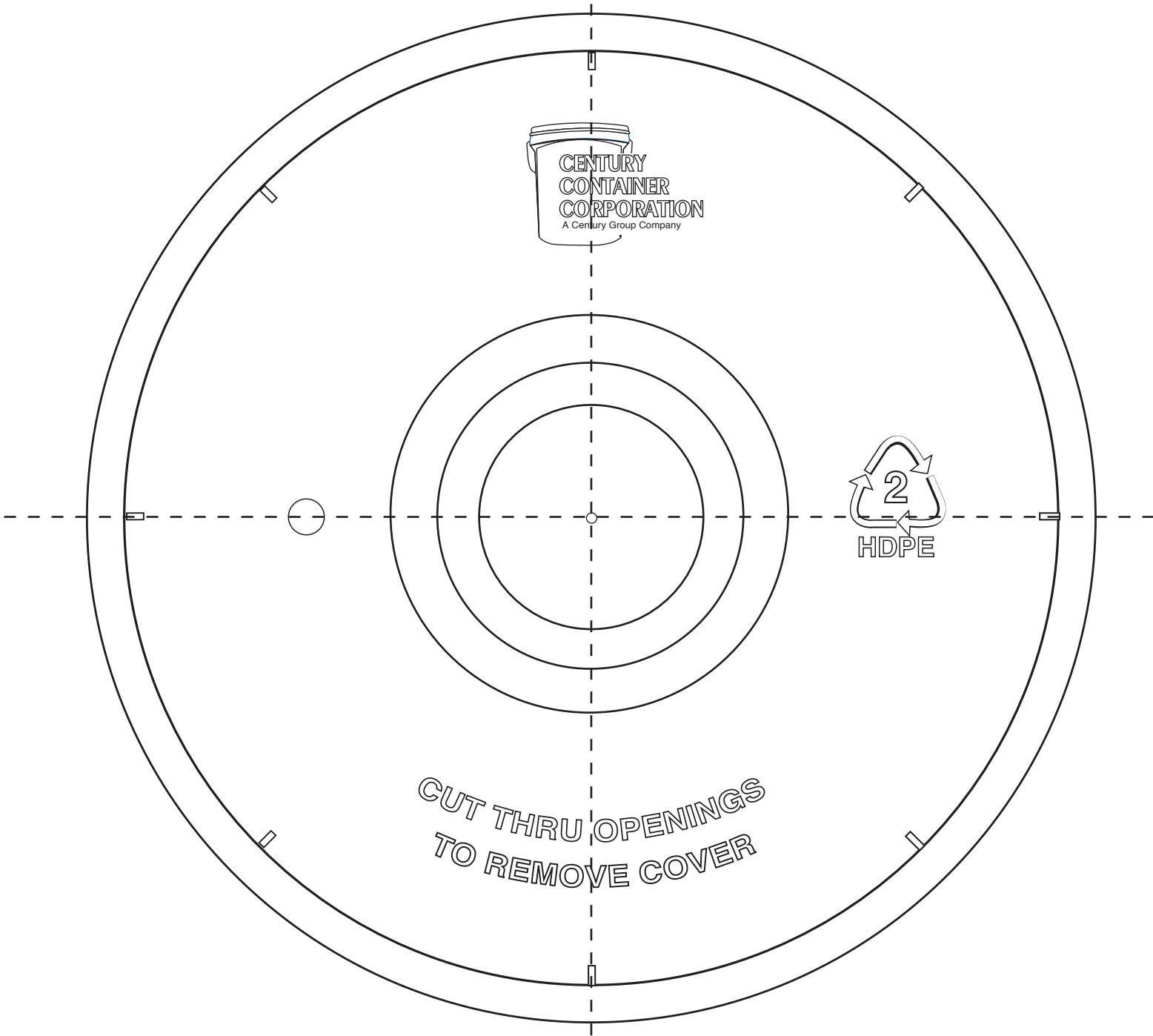



Engineering Specification

CAVITY 67 PART NUMBER: 205667

Standard Lid with Gasket

SPECIFICATIONS

Top Outer Diameter: 12.070"
 Top Out of Round: 1/8" max
 Height: 1.072"
 Wall Thickness: .090"
 Weight: 255 grams

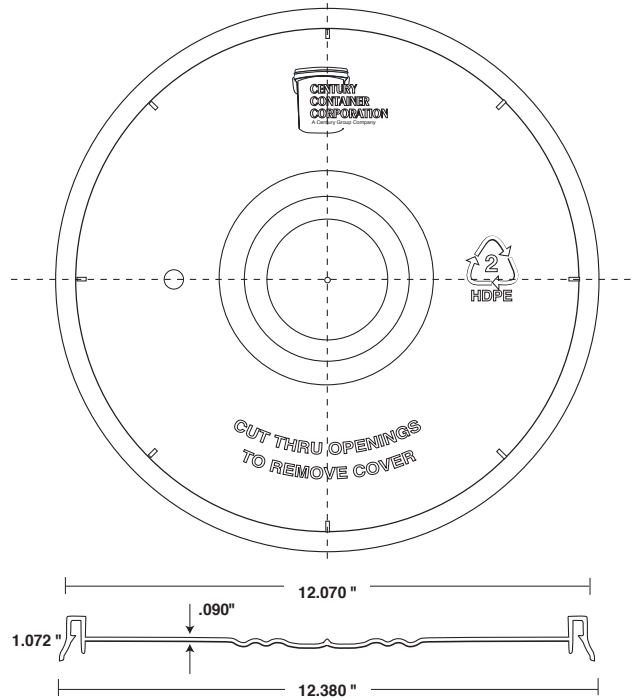

COMPONENTS

Resin: Prime High Density Polyethylene (HDPE)
 Color: Per customer spec
 Gasket: PVC or EPDM

PRINT SPECIFICATIONS

N/A

STANDARD PACKAGING

168 per pack (12 stacks of 14 each).
 Trays on top and bottom with stretch wrap.
 Applied label shows Part Number and Color, Date, Packaging Quantity, Shift.
 Package Dimensions: 37 1/2" x 50" x 12 1/2"
 Weight: 100 lbs. Bulk Density: 7.37 lbs./cubic ft.

OPTIONS

FDA 21 CFR 177.1520(c)3.2(a)
 European Union 2002/72 EC

CORRESPONDING PAILS

Part #	Description
203105	3.5 Gallon Pail
203106	3.9 Gallon Pail
205112	Short 5 Gallon Pail
205120	5 Gallon 70 mil Pail
205122	5 Gallon Standard Pail
205140	5 Gallon Pail
206146	6 Gallon Pail
205148	20 Liter Pail

LID OPTIONS

Rieke Spout
 Rieke Jr.
 Tint Plug