

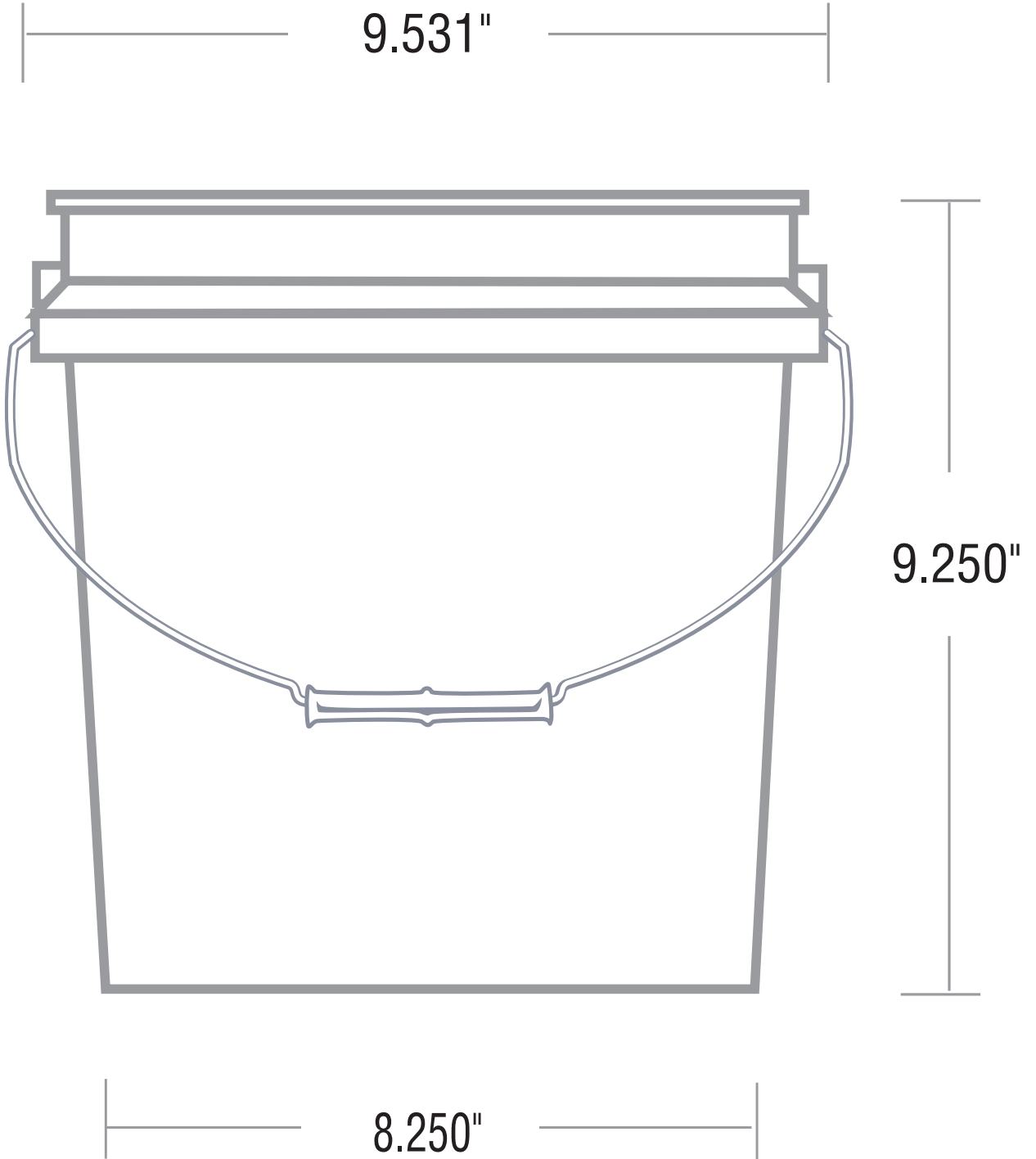

PART NO.: 202104

### 2 Gallon Open Head Plastic Pail





# Engineering Specification

**CAVITY 04**

**PART NUMBER: 202104**

2 Gallon Open Head Plastic Pail

**SPECIFICATIONS**

Top Outer Diameter: 9.531" +/- 0.031"  
 Top Out of Round: 0.125" max  
 Height: 9.250" +/- 0.125"  
 Wall Thickness: 65 mil  
 Weight: 340 grams +/- 5 grams  
 Overflow Capacity: 2 gallons 64 ounces

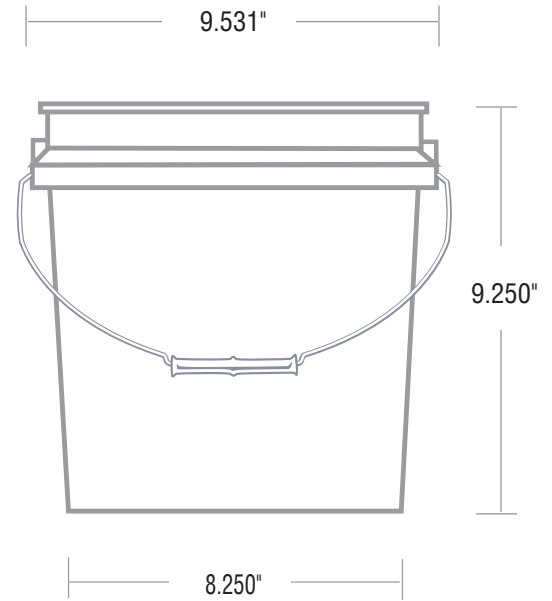

**COMPONENTS**

Resin: Prime High Density Polyethylene (HDPE)  
 Color: Per customer spec  
 Handle: 10 gauge galvanized wire with injection molded no-mark plastic grip

**PRINT SPECIFICATIONS**

Offset Printing Area: 6 1/4" x 28 1/4"  
 Four color maximum.  
 All pails are shipped flame-treated.

**STANDARD PACKAGING**

234 per pack (18 stacks of 13 each).  
 Pails packed top side up.  
 Trays on top and bottom with stretch wrap.  
 Applied label shows Part Number and Color, Date, Package Quantity, Shift.  
 Package Dimensions: 37" x 49" x 33 1/2"  
 Weight: 204 lbs. Bulk Density: 5.81 lbs./cubic ft.  
 Truckload Quantities: 18,252 (with Cavity 54 lid).

**OPTIONS**

FDA 21 CFR 177.1520(c)3.2(a)  
 European Union 2002/72 EC

**CORRESPONDING LIDS**

Part #	Description
202553	Peel-Off Gasketless
202554	Tear-Tab with Gasket

**LID OPTIONS**

Rieke Jr.  
 Tint Plug